



Electromagnetic Mould Level Coils

RT-1000 Series

The Radiametrics coil is designed to provide detection of steel level in continuous casting applications. The coil is protected from the molten steel by refractory and air-cooling. This coil works with 20 meter armored cable.

Main Features:

- Direct replacement coils for Nireco (NKK) mould level systems.
- Improved resistance to heat which allows for longer life and a more stable response.
- Reduced influence by electromagnetic interference.
- Steel measurement with improved deviation and fast response.
- Coil weight has been reduced to lessen vibrations from mould oscillation.
- Embedded temperature probe.
- Custom coil arms, 20 meter armored cables , and complete lines of refractory are available.
- Large cost reduction.



RT-1020S

RT-1040

Specifications:

Model	RT-1040	RT-1020S
Measurement Range	0-200mm	0-150mm
Internal Coil Dimensions	Ø40 X 100mm	Ø20 X 125mm
External Dimensions (with refractory)	Ø60 X 135mm	Ø28 X 140mm
Weight	0.7kg	0.4kg
Applications	Slab	Thinstrip Slab, Bloom

Drawings:

RT-1040

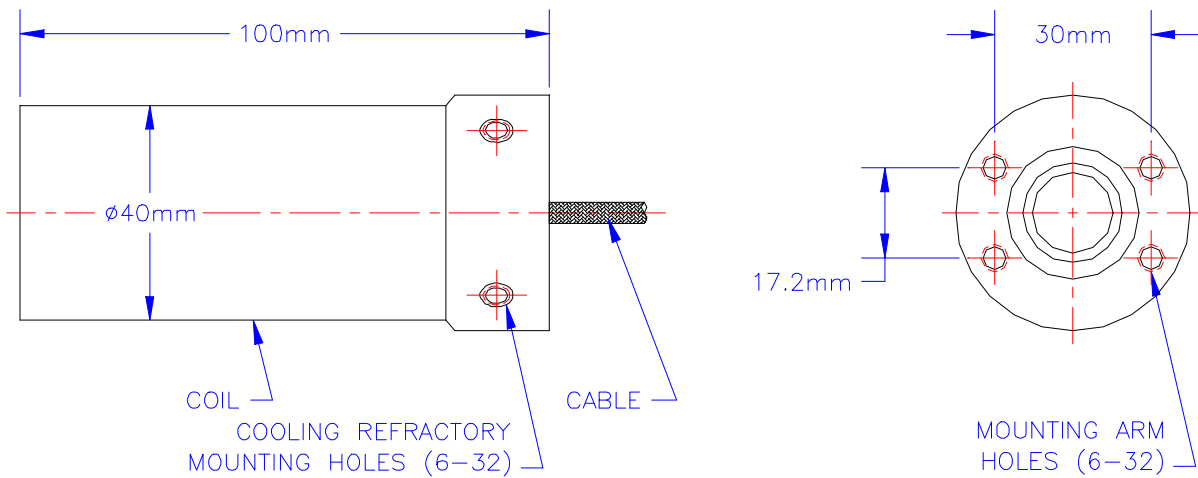

RT-1020S

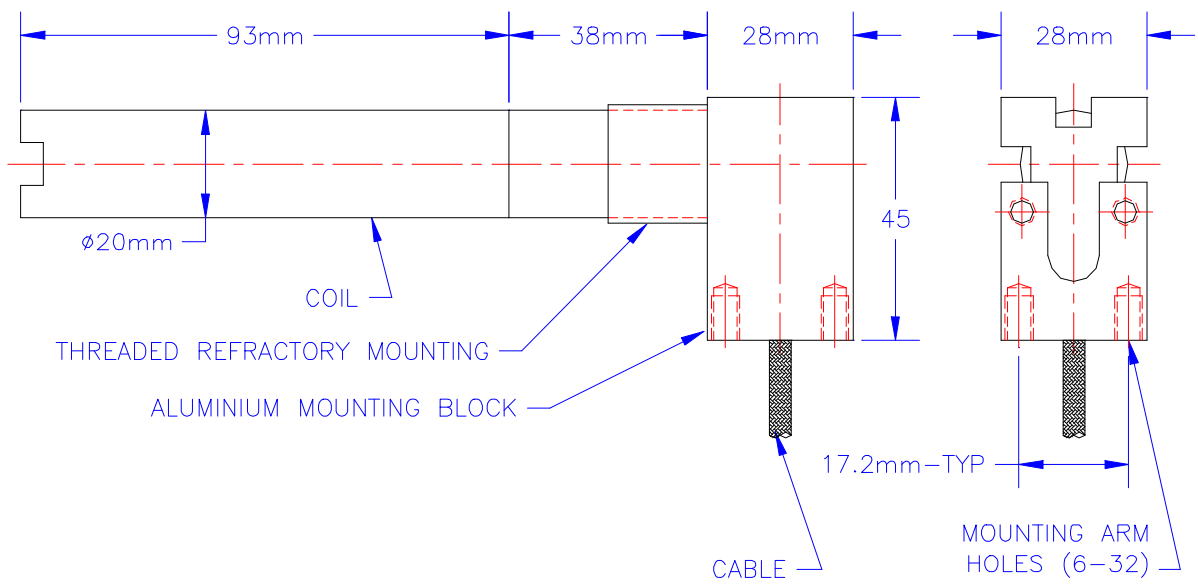

Drawings are shown NTS

Radiometrics Technologies
1215 Broadway Ave.
Lorain, Ohio 44052
Tel: (440) 245-9977
Fax: (440) 245-5538
www.radiometrics.com